

# ELECTRO-LUBER™

## INSTALLATION INSTRUCTIONS

### MICRO, MINI, BUDGET & JUMBO

#### Working Principle

When one or a combination of selector switches are turned on, an electro-chemical reactor cell is activated. This begins an electro-chemical reaction whereby electrical energy is converted into nitrogen gas. The gas is trapped in a hermetically sealed bellows-type gas chamber. As the gas is produced, an internal pressure builds up, which is applied against a piston. The piston then forces the lubricant out of the cylinder and into the lube point. The strength of the electrical current determines the amount of gas produced, which in turn, controls the rate of lubricant flow and the length of time the ELECTRO-LUBER™ will operate.

#### General Information

Each ELECTRO-LUBER™ is supplied with a **weather proof switch cap with O-ring which must be installed and tightened in all cases** as protection against weather and moisture. This cap **must** be kept on to ensure the intrinsic safety rating of the unit.

To ensure the success of your ELECTRO-LUBER™ installation, do not use in temperatures below -40° F or above 131° F (-40° C to 55° C), or in an application requiring more than 50 psi. The ELECTRO-LUBER™ is a single-point lubricator and is not designed to feed more than one bearing.

Install the ELECTRO-LUBER™, if possible, directly on the bearing. The ELECTRO-LUBER™ MICRO & MINI-LUBER™ have 1/4" NPT threads, the BUDGET-LUBER™ and JUMBO-LUBER™ have 1/2" NPT threads. To mount the ELECTRO-LUBER™ on bearings with different thread sizes use standard plumbing adapters or adapters available from A.T.S. ELECTRO-LUBE™.

For remote installation of ELECTRO-LUBER™ filled with grease use up to 3 feet of pipe or tubing with a minimum 1/4" ID (3/8" preferred). If oil is being used, line length may be up to 15 feet. Oil filled lubricators must be mounted with outlet pointed upward to avoid lubricant running out. If mounting oil filled lubricators with the outlet pointing downward, they must be used with a low pressure check valve.

High temperature lubricants, with a NLGI 2 rating, tend to harden at low temperatures and the lubricator cannot push them out. In low temperature applications use Lowtemp lubricants with NLGI 0 or 1 rating.

It is good practice to purge the bearing at every change out. If fittings or grease lines are used, these also should be filled with the same lubricant. Periodic inspections to check for the free flow of lubricant are necessary throughout the lifetime of the product.

Electro-lubers filled with lubricant have a shelf life of 1 year with a total life span of 2 years, however, this is not the case for every grease because each type of grease separates differently. For disposal, treat as hazardous waste and follow the regulations of your jurisdiction.

**Warning:** Wait 30 seconds after removing switch cap before operating any switches to ensure venting of the battery chamber.

**B-SWITCH** – Booster Switch – designed to make unit run 5% faster (can leave on through duration of setting).

#### Starting Procedure

At every installation, using a hand grease gun and the same type of grease, pump a few shots of lubricant into the bearing.

Select the dispensing time and amount of lubricant required, then click the appropriate switch or switches. This action closes a circuit and the gas generation begins.

Also click on the LED light switch. The LED light will soon flash and will repeat every 15 to 20 seconds for as long as the circuit is closed. The blinking of the LED light assures the system is in working order.

With the ELECTRO-LUBER™, **after the circuit is closed, there is a delay** before enough gas is formed to start moving the piston. The longer the dispensing period, the longer the delay.

**If continuous uninterrupted lubrication is required, "prestart" the ELECTRO-LUBER™ for 12 hours with all switches in the "ON" position. After this time return all switches to the "OFF" position except the ones for the chosen dispensing rate.**

If you do not "prestart" the delay time will be:

Time Delay to Dispense					
Month switch Setting	1 mo	2 mo	3mo	6 mo	12 mo
Delay in Hours To Start	18-24	40-48	60-70	120-140	240-280

1. Time selector switches, resistors and electronic circuit board.
2. Battery chamber with 2 x 1.5 volt Alkaline batteries.
3. Electrochemical cell and electrolyte.
4. Bellow gas chamber.
5. Piston.
6. Lubricant reservoir
7. Cylinder – nylon
8. Mounting nipple.
9. Outer plug.
10. "O" ring
11. Switch panel cap

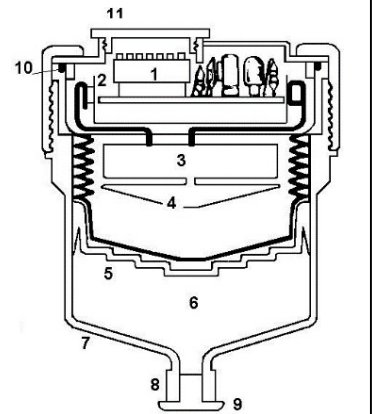

**MICRO-LUBER** dimensions 5" H x 3 1/8" Diameter  
**MINI-LUBER™** dimensions 5 5/8" H x 3 1/8" Diameter  
**BUDGET-LUBER™** dimensions 6 1/4" H x 4 1/8" Diameter  
**JUMBO-LUBER™** dimensions 6 3/4" H x 4 3/4" Diameter  
**TEMP. RANGE:** -40°F to 131°F (-40° C to 55°C)

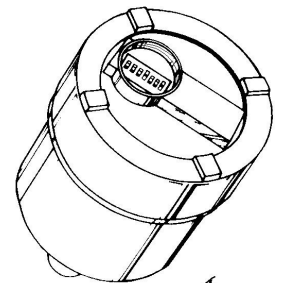
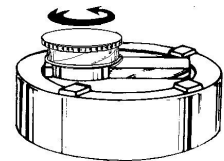

## Operating Procedure

If it is desired to increase or decrease the lubricant dispensing rate during operations, simply click the switch in use to OFF, Then click on the new switch setting.

To turn OFF the ELECTRO-LUBER™ during periods of shutdown click all switches, including the “LITE” switch, to OFF. It is not necessary to turn off the lubricator before disposal, simply remove from the bearing and dispose with your other used grease products.

Removing an ELECTRO-LUBER™ during operation will permit the discharge of lubricant until the point equilibrium in the expandable gas chamber is reached. In a bearing with no back pressure, no discharge will occur.

Proper maintenance inspection is vital to safe usage. The Electro-Luber has a built-in gas generator in which the pressure can build up to excess of 100 P.S.I.G. At this point, the top assembly may separate. In order to prevent this from happening, ensure free flow of lubricant, ie. Check for movement of orange piston during maintenance inspection.

Use of the product outside of stated parameters in this installation instruction sheet, including without limitation any blockage of the bearing preventing the free flow of lubricant, can cause the top of the unit to burst and result in bodily injury.

**NOTE – The lubricants dispensed by this equipment are to have flash points greater than 200° F.**

## To Prevent Accidents

**DO NOT** DISMANTLE DISCHARGED ELECTRO-LUBER™ (UNDER PRESSURE UP TO 50 PSI) WITHOUT FIRST PUNCTURING A HOLE THROUGH THE BOTTOM OUTLET (GREASE OUTLET), THROUGH THE PISTON AND INTO THE GAS CHAMBER TO RELIEVE THE PRESSURE.

## Comparison Chart

This chart compares the lubricant output rate of the ELECTRO-LUBER™ with several common manual lubrication schedules. The ELECTRO-LUBER™ switch setting indicated will provide comparable lubrication to that of the manual practice shown. Do not over-lubricate bearings.

Manual Lubrication Schedule	MICRO-LUBER Setting		MINI-LUBER Setting		BUDGET-LUBER Setting		JUMBO-LUBER Setting	
	Unit Life	Switch Setting	Unit Life	Switch Setting	Unit Life	Switch Setting	Unit Life	Switch Setting
Daily lubrication 3 – 4 strokes	.5 month		1 month		2 months		4 months	
2 – 3 day lubrication 3 – 4 strokes	1 month		2 months		4 months		8 months	
Weekly lubrication 8 – 10 strokes	1.5 months		3 months		6 months		12 months	
Bi-week lubrication 8-10 strokes	3 months		6 months		12 months			
Monthly lubrication 8-10 strokes	6 months		12 months					

NOTE: For above units, they can be emptied in 2 weeks by setting all DIP switches to the “ON” position.

## A “Rule of Thumb” for Switch Setting

This chart offers a “Rule for Thumb” for selecting appropriate switch settings and lubricant output rates for some basic applications. Many variables must be considered when determining the best setting for your operating environment. Areas of high contamination and heavy water washout generally require a slight increase in lubricant flow rate. The settings shown below are based on an average ambient operating temperature of 68° Fahrenheit. Please consult the temperature chart on the following page for using your ELECTRO-LUBER™ in other temperature ranges. Because of the wide number of variables found in actual operating environments, this chart should only be considered as a guide in making a selection of the proper switch settings. ALWAYS AVOID OVER-LUBRICATING.

Bearing Shaft Size	MICRO-LUBER	
	Switch Setting	Days to Empty
4” to 4 ¾”		15
3 ¼” to 4”		30
2 ¾” to 3 ¼”		45
2 ¼” to 2 ¾”		90
1 ¾” to 2 ¼”		120

Bearing Shaft Size	MINI-LUBER	
	Switch Setting	Days to Empty
4 ¾” to 6 ½”		15
4” to 4 ¾”		30
3 ¼” to 4”		60
2 ¾” to 3 ¼”		90
2 ¼” to 2 ¾”		180
1 ¾” to 2 ¼”		360

"Rule of Thumb" continued

Bearing Shaft Size	BUDGET-LUBER	
	Switch Setting	Days to Empty
4 3/4" to 6 1/2"		30
4" to 4 3/4"		60
3 1/4" to 4"		120
2 3/4" to 3 1/4"		180
2 1/4" to 2 3/4"		360

Bearing Shaft Size	JUMBO-LUBER	
	Switch Setting	Days to Empty
12 to 14 3/4"		20
10 3/4" to 12"		30
8 1/2" to 10 3/4"		60
6 1/2" to 8 1/2"		90
4" to 6 1/2"		120
2 3/4" to 4"		360

## Adjustment for Temperature Variation

The ELECTRO-LUBER™ dispensing rate is calculated at 20° C (68° F) at sea level, and 14.7 PSI/G. However, as the temperature RISES, the dispensing rate INCREASES. As the temperature FALLS, the dispensing rate DECREASES. To calculate the dispensing rate of the ELECTRO-LUBER™ dispenser at higher or lower average temperatures refer to the following chart, and apply the factor to the charts on the last page.

		°F	°C	FACTOR	
Red Ring MOST EFFECTIVE OPERATING TEMPERATURES	Blue Ring MOST EFFECTIVE OPERATING TEMPERATURES	+131°	+55°	+35%	<b>Standard dispenser – maximum working life 90 days at 55° C (131° F)</b>
		+113°	+45°	+30%	
		+104°	+40°	+20%	<b>EXAMPLE 1</b> A "30 day" unit installed at 40° C will empty 20% faster (24 day discharge).
		+95°	+35°	+15%	
		+86°	+30°	+10%	
		+77°	+25°	+5%	
		+68°	+20°	Stable	
		+59°	+15°	-5%	
		+50°	+10°	-10%	<b>EXAMPLE 2</b> A "30 day" unit installed at -30° C has a 50% dispensing rate loss (45 day discharge).
		+41°	+5°	-15%	
+32°	0°	-20%	<b>Standard dispensing will function normally to a temperature of -40° C (-40° F).</b>		
+23°	-5°	-25%			
+14°	-10°	-30%			
+3.2°	-16°	-35%			
-4.0°	-20°	-40%			
-14.8°	-26°	-45%			
-22°	-30°	-50%			
-32.8°	-36°	-55%			
-40°	-40°	-60%			

## Adjustment for Altitude

The ELECTRO-LUBER™ operates in normal fashion at altitudes to 1000 feet above sea level. The dispensing rate will increase above 1000 feet due to reduced atmospheric pressure. For example, at 2000 feet the discharge rate will be 10% faster. For every additional 1000 feet of altitude the discharge rate will increase by an additional 5%. For applications at high elevations please request special instructions.

## Special Conditions for Safe Use

GROUP I - Certificate # MECS00ATEX4229X & IECEx BAS 11.0121X – THE ENCLOSURE DUST SEALS MUST BE MAINTAINED IN SERVICE.

GROUP II – Certificate # BAS00ATEX1228X & IECEx BAS 11.0120X – THE ENCLOSURE MATERIAL DOES NOT MEET THE SURFACE RESISTANCE REQUIREMENTS OF THE STANDARD, BUT THE SHAPE, DESIGN AND USAGE OF THE APPARATUS IS NOT CONSIDERED TO PRESENT A POTENTIAL ELECTROSTATIC RISK. THE APPARATUS MUST NOT BE INSTALLED IN A POSITION WHERE IT MAY BE SUBJECTED TO AN EXCESSIVE AIR/FLUID FLOW THAT COULD CAUSE AN ELECTROSTATIC CHARGE TO BUILD UP. A LABEL IS FIXED TO THE APPARATUS WARNING AGAINST RUBBING IN USE.

**ATEX UNITS – DO NOT LEAVE LITE SWITCH ON – IT IS ONLY MEANT FOR TESTING TO MAKE SURE UNIT IS WORKING DURING INITIAL INSTALLATION. CIRCUITBOARD HAS A SPECIAL LED RESISTOR TO COMPLY WITH ATEX INTRINSIC STANDARDS. TEST TO MAKE SURE LED BLINKS AND THEN TURN LITE SWITCH OFF.**

## Selection of Switch Settings

One stroke from a typical grease gun is equal to approximately one cubic centimetre (cc). To select the switch setting appropriate for your application first look across the temperature row for the approximate ambient temperature for the application. For fluctuating temperature applications, take the average between the high and the low temperature. Next, look down the column for the desired output of lubricant, remembering that 1 cc is equal to approximately one stroke from a grease gun. The switch settings are shown in the left most column.

### MINI-LUBER™ (125cc)

Lubricant output rates for various temperatures at altitudes from sea level to 1000 feet

Switch settings	+14°F		+32°F		+50°F		+68°F		+77°F		+86°F		+95°F		+113°F		+131°F	
	Daily output cc's	Days until empty	Daily output cc's	Days until empty	Daily output cc's	Days until empty	Daily output cc's	Days until empty	Daily output cc's	Days until empty	Daily output cc's	Days until empty	Daily output cc's	Days until empty	Daily output cc's	Days until empty	Daily output cc's	Days until empty
All	6.0	20	6.8	18	7.7	16	8.5	14.2	8.9	13	9.4	13	9.8	12	10.6	11	11.1	11
1	2.8	43	3.2	38	3.6	33	4.0	30	4.2	29	4.4	27	4.6	26	5.0	24	5.2	23
2	1.4	86	1.6	75	1.8	67	2.0	60	2.1	57	2.2	55	2.3	52	2.5	48	2.6	46
3	0.9	129	1.1	113	1.2	100	1.33	90	1.4	86	1.5	82	1.5	78	1.7	72	1.7	69
6+12	0.7	171	0.8	150	0.9	133	1.0	120	1.1	114	1.1	109	1.2	104	1.3	96	1.3	92
6+B	0.6	190	0.7	167	0.8	148	0.9	133	0.9	127	1.0	121	1.0	116	1.1	107	1.2	103
6	0.5	256	0.5	224	0.6	199	0.67	180	0.7	171	0.7	163	0.8	156	0.8	143	0.9	136
12+B	0.4	343	0.4	300	0.5	267	0.5	240	0.5	229	0.6	218	0.6	209	0.6	192	0.7	185
12	0.2	519	0.3	455	0.3	404	0.33	360	0.3	346	0.4	331	0.4	316	0.4	291	0.4	280

### BUDGET-LUBER™ (250cc)

Lubricant output rates for various temperatures at altitudes from sea level to 1000 feet

Switch settings	+14°F		+32°F		+50°F		+68°F		+77°F		+86°F		+95°F		+113°F		+131°F	
	Daily output cc's	Days until empty	Daily output cc's	Days until empty	Daily output cc's	Days until empty	Daily output cc's	Days until empty	Daily output cc's	Days until empty	Daily output cc's	Days until empty	Daily output cc's	Days until empty	Daily output cc's	Days until empty	Daily output cc's	Days until empty
All	12.5	20	13.9	18	15.6	16	17.4	14.2	19.0	13	19.2	13	20.6	12	22.0	11	22.7	11
1	5.8	43	6.6	38	7.6	33	8.3	30	8.6	29	9.3	27	9.6	26	10.4	24	10.8	23
2	2.9	86	3.3	75	3.7	67	4.1	60	4.4	57	4.5	55	4.8	52	5.2	48	5.4	46
3	1.9	129	2.2	113	2.5	100	2.7	90	2.9	86	3.0	82	3.2	78	3.5	72	3.6	69
6+12	1.5	171	1.7	150	1.9	133	2.0	120	2.2	114	2.3	109	2.4	104	2.6	96	2.7	92
6+B	1.3	190	1.5	167	1.7	148	1.8	133	2.0	127	2.1	121	2.2	116	2.3	107	2.4	103
6	1.0	256	1.1	224	1.3	199	1.3	180	1.5	171	1.5	163	1.6	156	1.7	143	1.8	136
12+B	0.7	343	0.8	300	0.9	267	1.0	240	1.1	229	1.1	218	1.2	209	1.3	192	1.4	185
12	0.5	519	0.6	455	0.6	404	0.7	360	0.7	346	0.8	331	0.8	316	0.9	291	0.9	280

### JUMBO-LUBER™ (475cc)

Lubricant output rates for various temperatures at altitudes from sea level to 1000 feet

Switch settings	+14°F		+32°F		+50°F		+68°F		+77°F		+86°F		+95°F		+113°F		+131°F	
	Daily output cc's	Days until empty	Daily output cc's	Days until empty	Daily output cc's	Days until empty	Daily output cc's	Days until empty	Daily output cc's	Days until empty	Daily output cc's	Days until empty	Daily output cc's	Days until empty	Daily output cc's	Days until empty	Daily output cc's	Days until empty
All	22.3	20	25.5	18	28.7	16	31.8	14.2	33.5	13	35.1	13	36.7	12	39.8	11	43.5	10
1	10.5	43	12.0	37	13.5	33	15.0	30	15.8	28	16.5	27	17.3	26	18.8	24	20.5	22
2	5.3	86	6.0	74	6.8	66	7.5	60	7.9	57	8.3	54	8.6	52	9.4	48	10.2	44
3	3.5	128	4.0	112	4.5	99	5.0	90	5.3	85	5.5	81	5.8	78	6.3	71	6.8	65
6+12	2.6	171	3.0	150	3.4	133	3.7	120	3.9	114	4.1	109	4.3	104	4.7	96	5.1	88
6+B	2.4	190	2.7	166	3.0	148	3.4	133	3.5	127	3.7	121	3.9	116	4.2	106	4.6	97
6	1.8	255	2.0	223	2.3	198	2.5	180	2.6	170	2.8	162	2.9	155	3.1	143	3.4	131
12+B	1.3	337	1.5	295	1.7	262	1.9	240	2.0	225	2.1	214	2.2	205	2.4	189	2.6	173
12	0.9	510	1.0	447	1.1	397	1.25	360	1.3	340	1.4	325	1.4	311	1.6	286	1.7	262

**Note: Please refer to previous page for temperature and altitude adjustments**

For other settings or special applications, please consult the factory or check our website for your nearest Distributor.

Certified Intrinsically Safe for Class I, Groups A,B,C,D; Class II, Groups E,F,G; Class III, UL #E149679, MSHA #2G-4081-0

Certificate # MECS 00 ATEX 4229X/1  
IECEx BAS 11.0121X

BAS 00 ATEX 1228X/2  
IECEx BAS 11.0120X

BSI EN ISO 9001:2015  
FM 66860

ANZEx 12.2005X  
Ex ia I Ma (-40°C ≤ Ta ≤ +55°C)  
Standards: EN60079-0: 2012 +  
A11:2013 and EN60079-11:2012

 I M1 Ex ia I Ma (-40°C ≤ Ta ≤ 55°C)  II 1G Ex ia IIC T3 Ga (-40°C ≤ Ta ≤ 55°C)

Harmonized Standards: EN60079-0:2012 + A11:2013 and EN60079-11:2012



**A.T.S. ELECTRO-LUBE INTERNATIONAL INC.**

7388 Wilson Avenue

Delta, British Columbia V4G 1H3 CANADA

Phone 604-946-1308 Fax 604-946-0427

**FACTORY DIRECT**

Phone: 1-800-663-8141

Fax: 1-800-663-8140

E.&O.E.

Rev. 11/20

A.T.S. Electro-Lube International Inc. has a limited warranty.  
The full text of the warranty can be found on our website:  
[www.atselectrolube.com](http://www.atselectrolube.com)